

THE STRUCTURE OF CLASSIFIER-MODIFIER RECURSION IN THAI¹

Khanin Chaiphet
Stony Brook University
khanin.chaiphet@stonybrook.edu

Abstract

The repeating classifier-modifier sequence that occurs within Thai nominals has been analyzed as an additional projection of ClassifierP with mandatory movement operations (Singhapreecha 2001). It has also been suggested that there is a prosodic break preceding it, hence requiring recourse to apposition (Visonyangoon 2000 and Jenks 2011). This study provides experimental support for the structures of the Thai nominals containing one, two, three and four classifier-modifier sequences. The results from the attachment experiment reveal that the number of the sequences affects how the speakers comprehend the nominals and that their comprehension differences reflect two divergent syntactic structures. For the nominals with one classifier-modifier sequence, the sequence tends to attach the lower DP in the structure while those with two classifier-modifier sequences are likely to be ambiguous between high and low attachment interpretations. Following the results of the relative clause attachment experiment in Dillon et al. 2018, I propose that both of these nominals have embedded structures similar to restrictive relative clauses and the entire DP subsequently undergoes obligatory roll-up movement. For those with three and four classifier-modifier sequences, the preference for high attachment suggests that these sequences should be analyzed as appositive phrases.

Keywords: classifiers, modifiers, appositives, attachment preference, Thai

ISO 639-3 codes: tha

1 Introduction

Topics on Thai nominals have received a great deal of attention from many syntacticians and semanticists (Visonyangoon 2000, Kookiattikoon 2001, Singhapreecha 2001, Piriya-wiboon 2010, Jenks 2011, among others). In their work, classifiers and modifiers are inclusively taken into account as they play a crucial role in the discussion of Thai nominals. Piriya-wiboon (2010:123), for example, proposes the default order of nominal modifiers, as in (1). The example for such an order is illustrated in (2).

- (1) Adjective > Numeral > Relative Clause > Demonstrative
 (2) *sûa* [_{Adj} *sǐ:dɛ:ŋ*] [_{Num} *nùŋ*] *tua* [_{RC} *thǐ: chán sú: ma:*] [_{Dem} *nán*]²
 shirt red one CLF that I buy ASP Dem
 ‘that one red shirt that I have bought’

The complex nominal in (2) contains a head noun *sûa* ‘shirt’, which precedes all of its dependents (an adjective *sǐ:dɛ:ŋ* ‘red’, a numeral-classifier sequence *nùŋ tua* ‘one’, a relative clause *thǐ: chán sú: ma:* ‘that I have

¹ I would like to express my gratitude to Francisco Ordóñez, Daniel Finer, Jiwon Yun, Raksit T. Lau-Preechathammarach, Grace B. Wivell, and two anonymous JSEALS reviewers, who painstakingly commented on earlier versions of this paper. I am also grateful to audiences at SEALS29 held in Tokyo, Japan, May 27-29, 2019. I alone am responsible for any remaining errors.

² Aspiration is not superscripted and /tɛ/ is represented as /c/ throughout this paper.

bought’, and the demonstrative *nán* ‘that’)³. Note that bare nouns in Thai are always ambiguous between numbers (singular vs. plural) and between specificities (specific vs. non-specific), but the addition of the modifying materials results in different interpretations. The examples of nominal modifiers and their interpretations are listed in (3).

- (3) Nominal modifiers
- a. **Noun + Adjective**
 sũa sǐ:dɛ:ŋ
 shirt red
 ‘the/a red shirt(s)’ *number & specificity ambiguities*
- b. **Noun + Numeral CLF**
 sũa nùŋ/sǎ:m/síp tua
 shirt one/three/ten CLF
 ‘(the) one/three/ten red shirt(s)’ *specificity ambiguities*
- c. **Noun + Relative Clause**
 sũa thî: chán sú: ma:
 shirt that I buy ASP
 ‘the/a shirt(s) that I have bought’ *number & specificity ambiguities*
- d. **Noun + Demonstrative**
 sũa nán
 shirt Dem
 ‘that/those shirt(s)’ *number ambiguities*

Just like bare nouns, (3a) and (3c) are ambiguous between being singular and plural as well as being specific and non-specific. The numeral-classifier sequence in (3b) has no number ambiguities since it is already specified by an overt numeral. Similarly, (3d) has no specificity ambiguities because the demonstrative is present in the phrase.

We can see from (3) that only the numeral obligatorily requires the classifier while the other modifiers can occur freely with the head noun. The list in (4) illustrates the cases in which the classifier optionally occurs with the adjective (4a), relative clause (4c) and demonstrative (4d), leading to the singular-and-specific interpretation. Note that, unlike the numeral in (3b) (repeated in (4b)), the classifier must precede the modifier.

- (4) Classifier-modifier (‘CLF-Mod’ henceforth) constructions⁴
- a. **Noun + CLF Adjective**
 sũa tua sǐ:dɛ:ŋ
 shirt CLF red
 ‘the (one) red shirt’ *singular and specific*
- b. **Noun + Numeral CLF**
 sũa nùŋ/sǎ:m/síp tua
 shirt one/three/ten CLF
 ‘(the) one/three/ten red shirt(s)’ *specificity ambiguities*

³ The DP-internal modifiers we investigate in this study are those that appear in the complex noun phrase proposed by Piriyawiboon (2010: 123). There are also other kinds of such modifiers including prepositional phrases, genitive phrases, and the *wh*-indeterminate element *nǎj* ‘which’.

⁴ While the CLF Adjective and CLF Demonstrative sequences are analyzed as adjuncts to ClassifierP, evidence from NP-ellipsis suggests that numerals should be analyzed as Spec, ClassifierP (Jenks 2011). Moreover, Jenks’ notion of ‘classifier-modifier construction’ only includes those that are complements to the null choice functional determiner (D_{CF}). I, however, consider all co-occurrences of a modifier and a classifier as classifier-modifier constructions in this paper.

c. **Noun + CLF Relative Clause**

sûa tua thí: chán sú: ma:
 shirt CLF that I buy ASP
 ‘the (one) shirt that I have bought’

singular and specific

d. **Noun + CLF Demonstrative**

sûa tua nán
 shirt CLF Dem
 ‘that (one) shirt’

singular and specific

While the classified/modified nominals in Thai have been explored in great detail both syntactically and semantically, only Singhapreecha (2001) has formally accounted for a fact that a CLF-Mod sequence can also be repeated within the same nominal. Visonyangoon (2000) and Jenks (2011) also suggest a possible analysis with respect to multiple occurrences of a CLF-Mod sequence. Yet these scholars refer to the nominals containing only one repeating CLF-Mod sequence.

Since there is evidence that a CLF-Mod sequence can be repeated, one might expect its multiple occurrences within a single nominal similar to (2). Just like (2), all of these CLF-Mod sequences would modify the same head noun in the leftmost position of the nominal. The combination of the CLF-Mod constructions in (4a-d) is illustrated in (5).

- (5) sûa [tua [Adj sǎ:dɛ:ŋ]] [[Num nùŋ] tua] [tua [RC thí: chán sú: ma:]] [tua [Dem nán]]
 shirt CLF red one CLF CLF that I buy ASP CLF Dem
 ‘that one red shirt that I have bought’

The interpretation of the nominal in (5) is somewhat similar to the one in (2), except that (5) sounds less natural and might not be used regularly by the speakers. Its interpretation also carries an excessively emphatic sense. It could have been concluded that this emphatic meaning was due to the semantics of the classifier itself and thus the fact that the nominal contains too many classifiers made it less acceptable. If this assumption about the number of classifiers is correct, we would expect the same judgment for any nominals containing many classifiers. However, this is not true for the following nominal.

- (6) naj ka:nrɔp khráŋ ní: raw cà? mi: kɔ:ŋtháp jɔ:j [há: kɔ:ŋ] [sì: kɔ:ŋ]
 in battle time this we will have troop small five CLF four CLF
 [sǎ:m kɔ:ŋ] lé? [sɔ:ŋ kɔ:ŋ]
 three CLF and two CLF
 ‘In the battle this time, we will have five, four, three and two small troops.’
 (Thai) ‘ในการรบครั้งนี้ เรามีกองทัพย่อยห้ากอง สี่กอง สามกอง และสองกอง’

(6) is obviously an instance of multiple nominal conjuncts separated by a space, as shown in the Thai translation. Although the nominal is packed with multiple classifiers, native speakers of Thai would not find them too emphatic or even redundant. Given that such a punctuation mark is required between each repetition of the CLF-Mod sequence, which in turn resolves the emphatic sounding of the nominal, one might raise a question as to whether spacing works the same way for the nominal in (5)⁵. According to the punctuation guidelines by the Royal Institute of Thailand, there is no clear and uniformed punctuation rule for this type of nominal, so, unlike (6), we have no ‘explicit’ clue as to how its structure would look like. That being the case, the sentence in (6) suggests that the less acceptability of multiple CLF-Mod sequences in Thai may be resolved by prosody.

⁵ Spacing serves as “explicit prosody” for readers (Wagner and Watson 2010). One way to examine the production of the repeating CLF-Mod sequences is to see whether the speakers produce a prosodic break between each repetition in their utterances, which may in turn provide potential cues to the syntactic structure. This, however, would not work with a nominal containing only two CLF-Mod sequences since the number of modifiers seems to affect the speakers’ decision on where a prosodic break should be inserted. Adding a prosodic break between those two sequences is definitely possible, but not necessarily required (*cf.* Visonyangoon 2000 and Jenks 2011).

To confirm my intuition on the emphasis and naturalness of this type of nominal, I conducted a brief, informal survey asking 38 native speakers of Thai their opinions on both the multiple-Mod nominal, as in (2), and the multiple-CLF-Mod nominal, as in (5). As expected, the result showed that 36 out of 38 speakers (94.74%) thought that the multiple-Mod nominal was normal. As for the multiple-CLF-Mod nominal, the speakers provided some brief comments regarding the redundancy of the classifiers, agreeing with my initial judgment that its meaning carried an extremely emphatic sense. They further stated that such nominals were likely to appear only in literary contexts such as poems or song lyrics rather than daily conversations. Surprisingly, however, 30 out of 38 speakers (78.95%) judged the nominals perfectly fine and only eight speakers (21.05%) thought that these multiple-CLF-Mod nominals were bad or ungrammatical. The fact that such nominals are considered acceptable by the majority of the speakers despite being semantically dispreferred raises two important questions. First, would the number of CLF-Mod sequences affect how the speakers comprehend the sentence, and are there limits on repeating those sequences within the same nominal? Second, since the nominals are judged grammatical, it suggests that they seem to have well-formed, legitimate structures. How can we then account for these structures?

In the following section, I will explore two divergent views of the repeating CLF-Mod sequence in Thai, and construct hypotheses based on the data from those studies. Each view provides an idea on how the structure of the repeating CLF-Mod sequence should be built. In Section 3, I will present an experiment that investigates whether a CLF-Mod sequence behaves similarly to a restrictive relative clause or an appositive material by examining the speakers' preferences for syntactic attachment of the sequence. Its results are expected to address the questions on the number limits of the repeating classifiers as well as the structures of a nominal containing multiple CLF-Mod sequences in general. Section 4 concludes.

2 Some thoughts on multiple-classifier constructions

To my knowledge, only one study has thoroughly examined Thai nominals containing multiple CLF-Mod sequences while others refer to them briefly in their papers⁶. What we can infer from the overall discussion is that there could be two ways of analyzing this kind of nominals. The first way is to assume multiple projections of ClassifierP ('ClFP' henceforth) with mandatory movement operations, following Kayne (1994) (Singhapreecha 2001). The second way is to analyze the repeating CLF-Mod sequence as an appositive phrase since there seems to be a prosodic break between the first (the one closest to the head noun) and the following (repeating) CLF-Mod sequences (Visonyangoon 2000 and Jenks 2011)⁷. To distinguish between these two ways of analysis, I label the first one the 'Continuous Complex Nominals' view simply because such nominals do not involve the requirement of a prosodic break between each CLF-Mod sequence, implying that the sequence is probably subordinated below the head noun, somewhat similar to restrictive relative clauses. The second one is labelled the 'Paused Complex Nominals' view since a prosodic break is suggested to appear before the occurrence of the repeating CLF-Mod sequence. The detailed analyses of these studies are provided below.

⁶ These constructions are to be distinguished from those in Mandarin Chinese in that the two classifiers in Mandarin, although modifying the same head noun, must be in different types. For instance, if one is a Kind Classifier (KCL), the other has to be either an Individual Classifier (ICL) or a Mass Classifier (MCL). The example below is taken from Liao and Wang (2011:147).

- (i) a. Zhangsan you san chi zhe yi zhong gou
 Zhangsan have three ICL this one KCL dog
 'Zhangsan has three dogs of this breed.'
- b. Lisi gong he-le san wan na liang zhong tang
 Lisi totally drink-ASP three MCL that two KCL soup
 'Lisi totally drank three bowls of soup of the two different kinds.'

⁷ Again, Visonyangoon (2000) and Jenks (2011) did not investigate the nominals containing classifier recursion in detail. Visonyangoon only discusses them briefly in Footnote 4 of Chapter 4 (p. 105). Similarly, Jenks provides a brief suggestion on their potential analysis in Footnote 24 of Chapter 3 (p. 128-129) when referring to the co-occurrence of deictic modifiers.

2.1 Continuous Complex Nominals

The first analysis of complex nominals does not require a prosodic break between the first and second (repeating) CLF-Mod sequences. Each classifier is generated in the head position of its own ClfP. Singhapreecha (2001:267) provides an instance of this complex nominal and proposes its structure in (7).

- (7) a. nòk tua lèk sǎ:m tua nán
 bird CLF small three CLF Dem
 ‘those three small birds’

b.

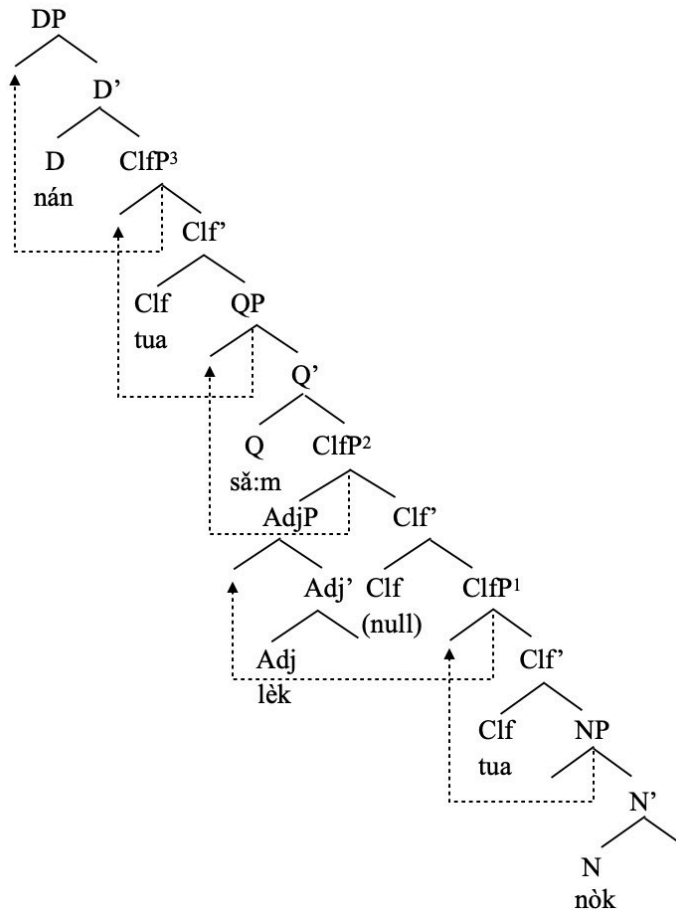

The structure in (7b) contains multiple ClfP projections, including the layered ClfP² for generating AdjP, and undergoes the mandatory roll-up movement operations to get the surface word order in Thai. This analysis follows Kayne's (1994) restrictive theory of word order where asymmetrical c-command relations play a crucial role in the linear precedence. While her analysis successfully accounts for the complex nominals in Thai, the arguments presented in Visonyangoon (2000) seem to undercut the existence of such complex nominals. Visonyangoon proposes that there are nouns that are coincidentally homophonous with and have the same distribution as numeral classifiers proper in Thai. According to her, these “classifier-like” nouns get modified by an adjective and the whole unit behaves like a compound adjective. To illustrate, the word *tua*, when used with human beings, is claimed not to be classifiers proper but actually a noun that combines with the adjective *lèk*, forming a compound adjective *tua lèk* ‘small-bodied’. They have the similar construction to English compound adjectives such as ‘*hard-cover* book’, ‘*blue-collar* job’ and ‘*white-tie* affair’. If such an argument holds true, (7) might no longer be complex, but rather a nominal containing a compound adjective and only one Num-CLF sequence. The similar analysis of Thai classifiers by Piriyaawiboon (2010) seems to agree with this point as she also analyzes the word *tua* that precedes the adjective as part of a nominal adjunct modifier describing the size of an object. Her representation also involves an obligatory roll-up movement. She additionally proposes that the head noun needs to raise to the top of the structure to check an

uninterpretable nominal feature in “Specific Phrase”. This SpecificP requires a ClfP to provide the quantifier to the noun phrase. The structure for this nominal is given in (8) (Piriyawiboon 2010:112).

- (8) a. mǎ: tua jǎj sǔ:ŋ tua
 dog body big two CLF
 ‘the two big dogs’

b.

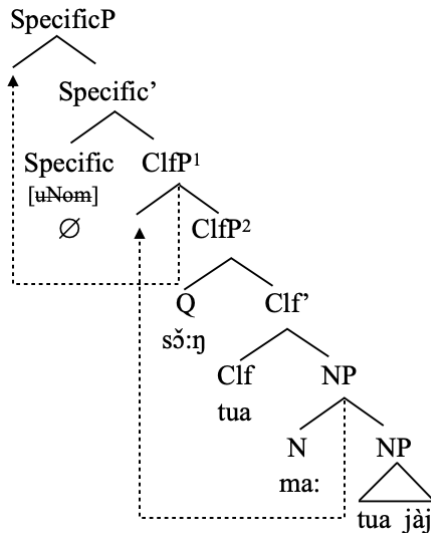

There are several pieces of evidence that support the argument that *tua* should not be counted as classifiers proper. First, Visonyanggoon shows that the word *tua* when used to describe a human being’s physical dimensions is actually a noun that denotes the meaning of ‘body’, as in (9a). The reason why *tua* is employed to form the compound adjective *tua sǔ:ŋ* ‘tall-bodied’ in this context is because its meaning is compatible only with this particular type of adjective. Therefore, if *tua* is used with the adjective that does not describe physical dimensions, such as *chalà:t* ‘smart’, as in (9b), the nominal will be unacceptable (2000:71-72).

- (9) a. phû:jǐŋ **tua** sǔ:ŋ
 woman body tall
 ‘the/a tall-bodied woman(-en)’
 b. *phû:jǐŋ **tua** chalà:t
 woman body smart
 ‘the (one) smart woman’ (Intended)
 c. phû:jǐŋ **khon** sǔ:ŋ
 woman CLF tall
 ‘the (one) tall woman’
 d. phû:jǐŋ **khon** chalà:t
 woman CLF smart
 ‘the (one) smart woman’

However, when the human classifier *khon* is employed, as in (9c) and (9d), the nominal is well-formed and only the singular-and-specific interpretation is obtained. Note also that the classifier *khon* can be used with any kinds of adjectives to denote a singular-and-specific interpretation while the noun *tua*, as in (9a), is always ambiguous between numbers and between specificities. This is actually not surprising if we assume that *tua* is part of a compound adjective modifying a bare noun.

We have seen the examples in (9) that *tua* should not be analyzed as a classifier because it functions differently from numeral classifiers proper in Thai: *tua* is used only with a specific kind of adjective (i.e., the adjective describing a physical dimension of human beings) and does not provide ‘only’ a singular-and-specific

interpretation. This argument, however, does not preclude the possibility that *tua* could function as classifiers proper when it is used with an animal. The examples in (10) show not only that *tua* behaves like a compound-adjective part, exhibiting ambiguous interpretations (between numbers and between specificities) as in (10a), it can also be used with the non-physical adjective *chalà:t* ‘smart’ and exhibits a singular-and-specific interpretation, similar to a classifier (10b; cf. 9b).

- (10) a. mǐ: tua sǔ:ŋ
 bear body tall
 ‘the/a tall-bodied bear(s)’
 b. mǐ: tua chalà:t
 bear CLF smart
 ‘the (one) smart bear’

Therefore, while it is clear that *tua* used with human beings should be analyzed as a compound-adjective part, it can behave as either a compound-adjective part or a classifier when used with animals or inanimate objects. When *tua* behaves as a classifier, it is able to classify a non-physical adjective and the ambiguities found in a compound-adjective part do not arise.

Second, only classifiers proper can be licensed by a quantifier. Since the compound-adjective part *tua* in (11b) is not a classifier, it is incompatible with a numeral quantifying a human being (Visonyangoon 2000:72). The nominal is well-formed only when *tua* is used with a numeral to quantify an animal, as in (11c).

- (11) a. phû:jǐŋ sǎ:m khon
 woman three CLF
 ‘(the) three tall women’
 b. *phû:jǐŋ sǎ:m tua
 woman three body
 ‘(the) three tall women’ (Intended)
 c. mǐ: sǎ:m tua
 bear three CLF
 ‘(the) three tall bears’

Third, the fact that *tua sǔ:ŋ* can be used predicatively in (12a) suggests that it functions the same as an attributive adjective. On the other hand, (12b) shows that, as a classifier, *khon* cannot be used as a predicate (Visonyangoon 2000:73).

- (12) a. phû:jǐŋ khon nán **tua** **sǔ:ŋ**
 woman CLF Dem **body** **tall**
 ‘That woman is tall.’
 b. phû:jǐŋ khon nán **khon** **sǔ:ŋ**
 woman CLF Dem **CLF** **tall**
 *‘That woman is tall.’

Next, in the case in which there are two CLF-Mod sequences within the same nominal, the preceding CLF-Mod sequence must not have a number contradiction with the following one. (13a) shows that the compound adjective *tua sǔ:ŋ* does not contradict in number with the following *sǎ:m khon* sequence because *tua* is not classifiers proper and thus allows a plural reading compatible with *sǎ:m khon*. However, the preceding CLF-Mod sequence *khon sǔ:ŋ* in (13b) contains the classifier *khon*, which exhibits a singular-and-specific interpretation, so it fails to be co-interpreted with the following *sǎ:m khon* sequence. Such a contradiction is lost when the preceding sequence contains the numeral *nùŋ* ‘one’, exhibiting a singular interpretation, as in (13c).

- (13) a. phû:jǐŋ [tua sǔ:ŋ] [sǎ:m khon]
 woman body tall three CLF
 ‘(the) three tall women’
 b. #phû:jǐŋ [khon sǔ:ŋ] [sǎ:m khon]
 woman CLF tall three CLF
 ‘(the) three tall women’
 c. phû:jǐŋ [khon sǔ:ŋ] [nùŋ khon]
 woman CLF tall one CLF
 ‘the one tall women’

The last argument comes from my own observation on the co-occurrence of a classifier and a compound adjective within the same nominal. When they co-occur, the noun part of the compound adjective must be adjacent to the adjectival head. The nominals in (14) illustrate this claim while the ones in (15) show that they become ill-formed when the positions of a classifier and a compound-adjective part are switched.

- (14) a. phû:jǐŋ khon [tua sǔ:ŋ]
 woman CLF body tall
 ‘the (one) tall-bodied woman’
 b. lû:kpòŋ baj [soŋ klom]
 balloon CLF shape round
 ‘the (one) round-shaped balloon’
- (15) a. *phû:jǐŋ tua [khon sǔ:ŋ]
 woman body CLF tall
 ‘the (one) tall-bodied woman’
 b. *lû:kpòŋ soŋ [baj klom]
 balloon shape CLF round
 ‘the (one) round-shaped balloon’

In conclusion, the Continuous Complex Nominal view does not take the differences between classifiers proper and compound-adjective parts into consideration. The arguments presented above suggest that the nominals containing the *tua*-adjective sequence that modifies a noun denoting a human being are not actually complex and thus the multiple layered ClFP projections may not be necessary. To qualify as classifiers proper, the sequence must be interpreted as singular and specific as we have seen in the cases of the *khon*-adjective sequence and the *tua*-adjective sequence that modifies a noun denoting an animal or an inanimate object. Such a distinction should thus be reflected on the structures of these two types of nominals. We will return to this issue in Section 3.

2.2 Paused Complex Nominals

The second view of Thai complex nominals suggests that a prosodic break should be inserted between the first and the repeating CLF-Mod sequences. Since the break is needed, the repeating sequence should be analyzed as an appositive.

- (16) Visonyanggoon (2000:105, fn. 4)
 phû:jǐŋ khon sǔ:ŋ | khon nán
 woman CLF tall CLF Dem
 ‘the tall woman, (who is) that one’

(16) shows that the prosodic break is inserted between the CLF-Adjective and CLF-Demonstrative sequences. Visonyanggoon claims that these sequences are in fact two separate phrases because the prosodic break is mandatory and the repeating sequence *khon nán* has similar usage to appositives. Along the same lines, Jenks (2011) suggests that only a demonstrative can be licensed by multiple occurrences of the classifier and that the

CLF-Demonstrative sequence may also require recourse to apposition. Like (16), the repetition of the classifier in (17) may turn it into an appositive.

- (17) Jenks (2011:128-129, fn. 24)
 thúʔrian lû:k nùŋ [lû:k ní:]
 durian CLF one CLF Dem
 ‘this one durian’

The idea regarding appositives, however, brings up a couple of important issues. First, the insertion of a prosodic break before the repeating CLF-Mod sequence has never been empirically investigated and is not always salient to native speakers. Therefore, to analyze such a sequence as an appositive seems questionable and need a proper investigation. In order to detect appositives and tease them apart from restrictives, many scholars rely on apposition diagnostics such as the P Family Test (Chierchia and McConnell-Ginet 1990), Challengeability Test (Faller 2002), Answerability Test (Koev 2013), and so forth. What these tests show is that the content of an appositive relative clause is what being asserted (backgrounded information), not what being presupposed. In other words, appositive relative clauses cannot include presupposed information. In order to validate the claim about apposition in Thai, we could use these tests and see whether the repeating CLF-Mod sequence(s) would pattern with appositive relative clauses. Nevertheless, while the tests seem applicable to appositives in general, they cannot be applied to the multiple occurrences of the CLF-Mod sequence. Alternatively, there is a test (among many other tests) presented in Del Gobbo 2003 that distinguishes an appositive relative clause from a restrictive one on the basis of their co-occurrence within the same nominal. This test follows from the widely known property of postnominal relative clauses (Property VI, Del Gobbo 2003:59) that the restrictive relative clause is obligatorily positioned closer to the head noun than the appositive one when they co-occur (see also Jackendoff 1977, de Vries 2000, among others), exemplified in (18).

- (18) Property VI: Appositives appear DP-finally; hence, they follow all restrictive postnominal modifiers.
 a. The girl that I saw, **who John dislikes**, is beautiful.
 b. *The girl, who John dislikes, **that I saw** is beautiful.

Del Gobbo applied this test to the Mandarin Chinese counterpart of (18b) and found that, with respect to the demonstrative, the appositive relative clause needs to be closer to the head noun. She further proposes, along with the results from the other tests, that appositive relative clauses in Mandarin have the syntactic properties of restrictive relative clauses.

Turning back to Thai, the restrictive and appositive relative pronouns are expressed by two different words, *thî:* and *sûŋ* respectively. By applying the test in (18) to the relative clauses in Thai, it is found that Thai behaves exactly like English.

- (19) a. dèkphû:jǐŋ [thî: chán cə:] [sûŋ cə:n mâjchô:p] sǔaj
 Girl that I see which John dislike beautiful
 ‘The girl that I saw, who John dislikes, is beautiful.’
 b. *dèkphû:jǐŋ [sûŋ cə:n mâjchô:p] [thî: chán cə:] sǔaj
 girl which John dislike that I see beautiful
 ‘The girl, who John dislikes, that I saw is beautiful.’

Now let us replace the DP-final relative clauses in (19a) and (19b) with their corresponding CLF-Relative Clause sequences to see if they would pattern with (20a) and (20b) respectively. Our results show that while the sequence in (20a) patterns with the appositive relative clause in (19a), (20b) does not exhibit ungrammaticality, unlike (19b).

- (20) a. dèkphû:jǐŋ [thî: chán cə:] **[khon thî: cə:n mâjchô:p]** sǔaj
 girl that I see CLF that John dislike beautiful
 ‘The girl that I saw, who John dislikes, is beautiful.’
- b. dèkphû:jǐŋ [sûŋ cə:n mâjchô:p] **[khon thî: chán cə:]** sǔaj
 girl which John dislike CLF that I see beautiful
 ‘The girl, who John dislikes, who I saw, is beautiful.’

Following Property VI, the fact that the DP-final CLF-Relative Clause sequences in (20) are able to follow both restrictive and appositive relative clauses raises their possibility of being appositive phrases. However, that sequence in (20a) could alternatively be understood as a “stacked relative” (Carlson 1977, Grosu and Landman 1998), iterating the restrictive relative clause that precedes it. In fact, this CLF-Relative Clause sequence is not appositive by nature because it does not yield an appositive interpretation when it occurs alone in the nominal, unlike the appositive relative clause headed by *sûŋ*. On the other hand, (20b) is a more obvious case in which the CLF-Relative Clause sequence is being used as an appositive phrase because it can be preceded by an appositive relative clause. Thus, for the configuration in which two CLF-Relative Clause sequences co-occur, as illustrated in (21), it is unclear whether the repeating sequence (in bold) should be analyzed as a stacked relative or a DP-final appositive relative clause that follows the restrictive one. Hence, this test does not adequately confirm the assumption that the repeating CLF-Mod sequence ‘should’ be analyzed as apposition.

- (21) dèkphû:jǐŋ [khon thî: cə:n mâjchô:p] **[khon thî: chán cə:]** sǔaj
 girl CLF that John dislike CLF that I see beautiful
 ‘The girl that John dislikes that I saw is beautiful.’, *or*
 ‘The girl that John dislikes, who I saw, is beautiful.’

The second issue under this Paused Complex Nominal view is that the authors consider only the CLF-Demonstrative sequence as a repeating CLF-Mod sequence. In order to determine whether the repeating sequences could be analyzed as appositive phrases, the other types of modification as well as their possible combinations should also be taken into account. Therefore, I adopt the default order of the Thai nominal modifiers proposed by Piriyawiboon in (1) (repeated in (22)) to generate all of the possible combinations of sequences. Out of this modifier order, we could have six possible types of nominals containing two CLF-Mod sequences (23a), four containing three CLF-Mod sequences (23b), and one containing all four CLF-Mod sequences (23c). Note that the modifier order is rigid in Thai and there could potentially be dislocation effects if the order is not respected.

- (22) Adjective > Numeral > Relative Clause > Demonstrative

- (23) a. Two CLF-Mod sequences
- | | | | |
|----|------|---------------------|---------------------|
| 1) | Noun | CLF-Adjective | Numeral-CLF |
| 2) | Noun | CLF-Adjective | CLF-Relative Clause |
| 3) | Noun | CLF-Adjective | CLF-Demonstrative |
| 4) | Noun | Numeral-CLF | CLF-Relative Clause |
| 5) | Noun | Numeral-CLF | CLF-Demonstrative |
| 6) | Noun | CLF-Relative Clause | CLF-Demonstrative |
- b. Three CLF-Mod sequences
- | | | | | |
|----|------|---------------|---------------------|---------------------|
| 1) | Noun | CLF-Adjective | Numeral-CLF | CLF-Relative Clause |
| 2) | Noun | CLF-Adjective | Numeral-CLF | CLF-Demonstrative |
| 3) | Noun | CLF-Adjective | CLF-Relative Clause | CLF-Demonstrative |
| 4) | Noun | Numeral-CLF | CLF-Relative Clause | CLF-Demonstrative |
- c. Four CLF-Mod sequences
- | | | | | | |
|----|------|---------------|-------------|---------------------|-------------------|
| 1) | Noun | CLF-Adjective | Numeral-CLF | CLF-Relative Clause | CLF-Demonstrative |
|----|------|---------------|-------------|---------------------|-------------------|

In order to validate Visonyanggoon’s and Jenks’ suggestion that the CLF-Demonstrative sequence (and maybe other CLF-Mod sequences) is appositive, I will examine the possibility that the final (rightmost) repeating CLF-Mod sequences could behave like appositive phrases through an experiment on appositive relative clauses. My experiment will be presented in the following section.

3 Experiment

In this experiment, I attempt to address the following questions: (1) would the number of CLF-Mod sequences affect how Thai speakers comprehend a sentence, and (2) are there limits on repeating those sequences within the same nominal? We have seen in Section 2 that the previous studies provide a clue for our results in the claim that the repeating CLF-Mod (demonstrative) sequence may be analyzed as an appositive. If our results confirm this claim, it will be evident that the repetition of a CLF-Mod sequence may require recourse to apposition. The following hypotheses will thus be tested in the experiment.

- (24) **Hypothesis 1:** The nominal containing one CLF-Mod sequence (no repeating CLF-Mod sequence) is not appositive.
Hypothesis 2: If the nominal already contains one CLF-Mod sequence, adding the CLF-Demonstrative sequence would turn it into an appositive.
Hypothesis 3: If the nominal already contains one CLF-Mod sequence, adding another one (of any kind) may turn it into an appositive.
Hypothesis 4: If the second CLF-Mod sequence (the first repeating CLF-Mod sequence) is appositive, the third and fourth ones are also appositive.

My study essentially takes the results from the recent experiment by Dillon et al. (2018) as a first step toward seeing the empirical differences between appositive and restrictive relative clause attachment preferences. In their experiment, Dillon et al. investigate whether ambiguities in appositives can be comprehended similar to restrictive relative clauses in English. They compare three types of structures (restrictive relative clause, appositive relative clause and nominal appositive). Each structure also compares two prepositions (*of* and *with*). For the purpose of this study, I am only interested in the results from the sentence containing the preposition *of* since it provides clearer distinction between appositive and non-appositive materials. The list in (25) shows the stimuli constructed for their experiment. Table 1 illustrates the results (Dillon et al. 2018:6-7)

- (25) Penny ignored...
 a. ...the child of the patient that had an annoying voice. (*Restrictive relative clause*)
 b. ...the child of the patient, who had an annoying voice. (*Appositive relative clause*)
 c. ...the child of the patient, a young one with an annoying voice. (*Nominal Appositive*)

Table 1: Percentage of high attachment interpretations per condition

	Restrictive Relative Clause	Appositive Relative Clause	Nominal Appositive
High attachment interpretations	49	71	74

The experiment tests the preferences of high and low attachment interpretations for each modifier type in (25): it could possibly be attached high (associated with *the child*) or low (associated with *the patient*) in the structure. The results in Table 1 reveal that the speakers prefer the appositive relative clause and the nominal appositive to attach high, 71% and 74% respectively. The restrictive relative clause modifier receives 49% of the high attachment preference, suggesting that its presence exhibits ambiguities between high and low attachment interpretations. I will adopt the converse of this idea for the analysis of the CLF-Mod sequences in Thai. If the preference of high attachment is observed for such sequences, they are likely to be analyzed as

appositives. On the other hand, if the preferences between the high and low attachment interpretations similar to restrictive relative clauses are observed, the structure containing multiple CLF projections is more likely.

3.1 Method

3.1.1 Participants

80 participants (age 18–65) were recruited through various social networking services and volunteered approximately 15 minutes of their time without payment. They were adult native speakers of Thai who acquired Thai as their first language and speak Thai at home. The participation was anonymous. There was a short demographic questionnaire for the participants to fill out before starting the experiment.

3.1.2 Procedure and stimuli

The experiment crossed two factors: sequence number (single, double, triple, and quadruple) and intonation type (continuous and paused). The stimuli were presented through the online forms and surveys creator *Google Forms*. The 60 target items (2 nominals x 15 possible grammatical combinations of CLF-Mod sequences grouped into four number categories: 4 single, 6 double, 4 triple and 1 quadruple x 2 intonation types) were created through manipulation and divided into five sets to avoid repeated presentation of the same items as well as exhaustion. For each set, the 12 target items were pseudorandomized with 13 fillers (25 questions). The fillers were nominals containing different modifiers but lacked high vs. low attachment ambiguities. The first intonation type was represented by a continuous string of words (no spaces). It corresponded to the nominals within the Continuous Complex Nominal view in which a prosodic break was not present. The other intonation type was needed in order to confirm the high attachment preference. This appositive (high attachment) interpretation was reinforced by inserting a ‘space’ before the last repeating CLF-Mod sequence in the nominal. Note again that Thai orthography lacks spaces between words and that spaces are used like commas in Roman scripts. Three fillers were presented at the beginning of the experiment as a training session. In the case of the target items, participants were presented with a phrase/sentence and asked to choose which noun (high or low) the final CLF-Mod sequence corresponded to. All the instructions, questions and answers were constructed in Thai. (26) illustrates the examples of the stimuli with two intonation types (the space is shown in the Thai orthography in example (ii) of (26a)), and Table 2 lists all of the possible combinations of the CLF-Mod sequences.

(26) Stimuli

a. Target phrases

(i) Continuous string (no space)

เพื่อนของตำรวจคนที่ฉันแอบชอบคนนั้น

(ii) Paused string (with a space)

เพื่อนของตำรวจคนที่ฉันแอบชอบ คนนั้น

phǔn-an khǎːŋ tam-rùat [khon [RC thǐ: chán è:pchǎ:p]] [khon [Dem nán]]

friend of police CLF that I secretly.like CLF Dem

‘That friend of the police officer that I secretly like.’ *or*

‘The friend of **that** police officer that I secretly like.’

b. Question and answer choice

(i) Question: คำว่า “คนนั้น” หมายถึงใคร (Who does “*khon nán*” refer to?)

(ii) Answer: 1. เพื่อนของตำรวจ (The friend of the police officer)

2. ตำรวจ (The police officer)

Table 2: Possible combinations of CLF-Mod sequences with respect to the default order of nominal modifiers in Thai⁸.

Default modifier order (Piriyawiboon 2010: 123)	Adjective > Numeral > Relative Clause > Demonstrative
Single CLF-MOD sequence (No repeating sequence)	N1 of N2 CLF-Adj
	N1 of N2 Num-CLF
	N1 of N2 CLF-RC
	N1 of N2 CLF-Dem
Double CLF-MOD sequence	N1 of N2 CLF-Adj Num-CLF
	N1 of N2 CLF-Adj CLF-RC
	N1 of N2 CLF-Adj CLF-Dem
	N1 of N2 Num-CLF CLF-RC
	N1 of N2 Num-CLF CLF-Dem
	N1 of N2 CLF-RC CLF-Dem
Triple CLF-MOD sequence	N1 of N2 CLF-Adj Num-CLF CLF-RC
	N1 of N2 CLF-Adj Num-CLF CLF-Dem
	N1 of N2 CLF-Adj CLF-RC CLF-Dem
	N1 of N2 Num-CLF CLF-RC CLF-Dem
Quadruple CLF-MOD sequence	N1 of N2 CLF-Adj Num-CLF CLF-RC CLF-Dem

3.2 Results

Table 3 presents the percentage of high attachment preference judged by 80 native speakers of Thai. The results from the ‘continuous nominals’, the nominals containing one to four CLF-Mod sequences without an explicit prosodic break (i.e., the space) before the final CLF-Mod sequence are presented in parallel with the ‘paused nominals’, the ones with a space. Participants show an overall mean increase in preference for high attachment as the number of CLF-Mod sequences inside the nominals increases from one to four: the continuous nominals containing a single, double, triple and quadruple CLF-Mod sequence received a high attachment interpretation 34%, 42%, 68% and 78% of the time, respectively, while the paused ones did so 73%, 74%, 82% and 88% of the time, respectively. The bar chart in Figure 1 displays this comparison between the two intonation types (continuous vs. paused) while the ascending lines above the bars illustrate their increases in high attachment preference.

⁸ The target phrases were created from every possible combination of the modifiers with respect to their default order. What I did not investigate in this study was the case in which these modifiers were placed in different orders. Because the modifier order in Thai was quite rigid, it was likely that moving one up would turn the following into appositive phrases, regardless of the presence of a classifier. For example, if a demonstrative was placed in front of the other modifiers i.e., Noun > Demonstrative > Adjective > Numeral > Relative Clause, it would be treated as a topicalized element. The prosodic break would then be needed after this demonstrative and as such the elements following the break would turn into appositives.

Table 3: Percentage of high attachment (N1) preferences between continuous and paused nominals for the final CLF-Mod sequence of each possible combination.

Number of Sequence	Order	Continuous	Paused
		High (N1) %	High (N1) %
Single CLF-Mod sequence	N1 of N2 CLF-Adj	33	57
	N1 of N2 Num-CLF	25	86
	N1 of N2 CLF-RC	52	78
	N1 of N2 CLF-Dem	27	72
	MEAN	34	73
Double CLF-Mod sequence	N1 of N2 CLF-Adj Num-CLF	41	79
	N1 of N2 CLF-Adj CLF-RC	36	90
	N1 of N2 CLF-Adj CLF-Dem	44	59
	N1 of N2 Num-CLF CLF-RC	41	81
	N1 of N2 Num-CLF CLF-Dem	52	65
	N1 of N2 CLF-RC CLF-Dem	38	71
MEAN	42	74	
Triple CLF-Mod sequence	N1 of N2 CLF-Adj Num-CLF CLF-RC	73	84
	N1 of N2 CLF-Adj Num-CLF CLF-Dem	71	96
	N1 of N2 CLF-Adj CLF-RC CLF-Dem	63	68
	N1 of N2 Num-CLF CLF-RC CLF-Dem	63	79
	MEAN	68	82
Quadruple CLF-Mod sequence	N1 of N2 CLF-Adj Num-CLF CLF-RC CLF-Dem	78	88
	MEAN	78	88

Figure 1: Proportion of high attachment preference means between continuous and paused nominals for each group of the CLF-Mod sequences.

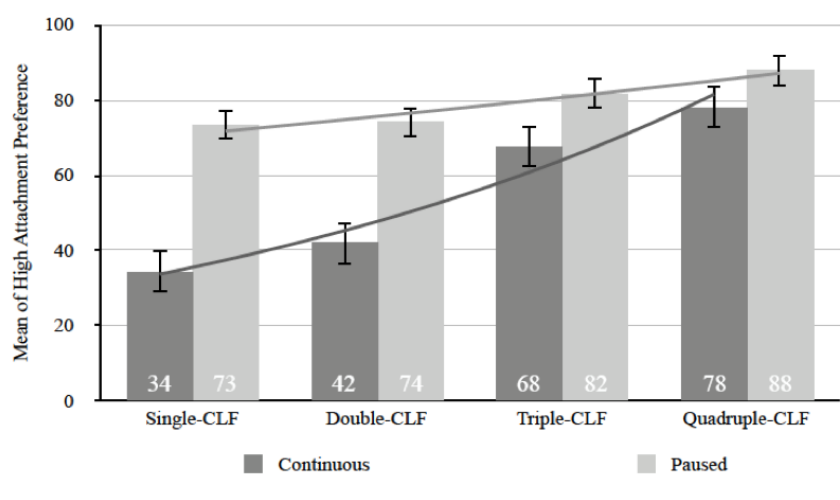

I fitted a Mixed Model Regression analysis in open-source code R with the lme4 library (Bates et al. 2014) to assess the statistical significance of the overall increase of the means of high attachment preference, summarized in Table 4. The primary prediction was confirmed. There was a significant effect of sequence number ($p=.002$): the preference for high attachment increases as the number of CLF-Mod sequences increases from one to four. I also found a very significant effect of intonation type ($p<.001$): more high attachment responses for the final CLF-Mod sequence of paused nominals than for that of continuous nominals. The interaction between intonation type and sequence number also reached statistical significance ($p<.001$), indicating that as the number of CLF-Mod sequences increases from one to four, the difference in the preference for high attachment between the two intonation types decrease: the more CLF-Mod sequences were added to the nominal, the more alike the high attachment preference results between the two intonation types became. I additionally explored the effect of modifier type for the final modifier and found no statistically significance ($p=.72$): the preference for high attachment does not depend on the type of the final modifier. The interaction of sequence number and modifier type was also not significant ($p=.61$).

Table 4: Mixed Model Regression on CLF-Mod recursion responses

Predictor	β	SE(β)	z	$p > z $
(Intercept)	-0.41	0.17	-2.37	
number	0.32	0.10	3.14	.002
intonation	0.51	0.07	6.91	<.001
final.modifier	0.01	0.04	0.35	.72
number:intonation	-0.11	0.03	-3.45	<.001
number:final.modifier	-0.01	0.02	-0.51	.61

3.3 Discussion

The results from Table 3 suggest that the paused nominals can potentially be analyzed as appositives, comparable to those results from Dillon et al. (2018). In fact, the relatively high preference for high attachment clearly shows that the interpretation of the complex nominals is very sensitive to an explicit prosody clue (i.e., a space). On the other hand, preference for high attachment was relatively low for continuous nominals since the space was not present. However, the participants showed a tendency toward a higher DP when more CLF-Mod sequences were added to the structure, suggesting two distinct structures for continuous nominals containing one (27a) and two (27b) CLF-Mod sequences, and those containing three (28a) and four (28b) CLF-

Mod sequences. Such distinction follows from the idea that restrictive and appositive relative clauses have different structures (Ross 1967, Thomson 1971, Jackendoff 1977, Rizzi 1997 and 2004). In the case of (27), since the percentage of the high attachment preference resembles the results from restrictive relative clauses in Dillon et al.'s experiment, I will assume a similar restrictive structure presented by Singhapreecha (2001) and Piriya-wiboon (2010) where there is a ClfP above NP to regulate obligatory roll-up movement operations, following Kayne (1994). In the case of the double CLF-Mod sequence, I assume another ClfP layer in the complement position of the D head.

(27) a. Single CLF-Mod sequence (No repeating sequence)

sûa [tua [Dem nán]]
 shirt CLF Dem
 ‘that shirt’

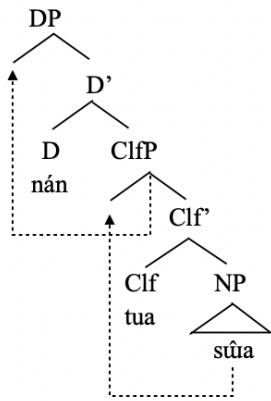

b. Double CLF-Mod sequence

sûa [tua [Adj sǐ:de:ŋ]] [tua [Dem nán]]
 shirt CLF red CLF Dem
 ‘that red shirt’

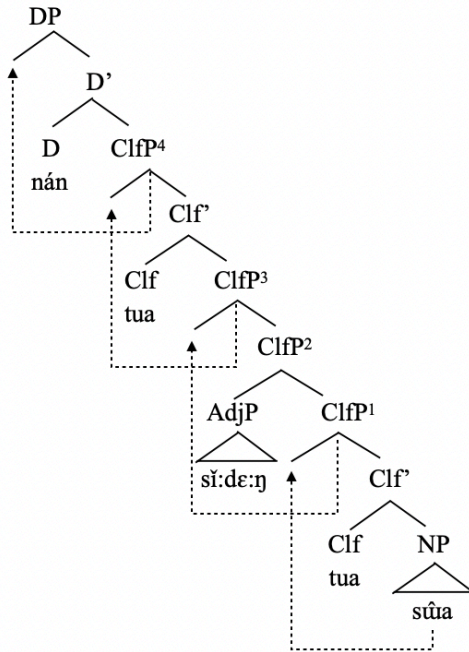

Note that even though the structure of the nominal containing two CLF-Mod sequences is assumed to be in parallel with that of a restrictive relative clause, the mean results of its final sequence (42% of the time) show that it is potentially ambiguous between high and low attachment interpretations. On the other hand, the mean

results for the triple and quadruple CLF-Mod sequences (68% and 78%, respectively) show that they are more likely to be analyzed as appositive, attaching to a higher DP. My structures for these CLF-Mod sequences follow the “Subordinate Clause Hypothesis”, which considers the appositive material to be in a local syntactic relationship with its host (e.g., Jackendoff 1977, Potts 2005, de Vries 2006, Dillon et al. 2018; cf. “Main Clause Hypothesis” e.g., Ross 1967, Thomson 1971, Schlenker 2010a and 2010b). I also adopt the claim that appositive constructions are “Force Phrases”, the pronounced postcopula elements that are used to perform speech acts (Rizzi 1997, Cinque 1999, Koev 2013). The structures in (28a) and (28b) illustrate the nominals containing three and four CLF-Mod sequences, respectively. Note that the first two CLF-Mod sequences are embedded inside the structure of the single DP just like those in (27).

(28) a. Triple CLF-Mod sequence

sũa [tua [Adj sǐ:dɛ:ŋ]] [[Num nùŋ] tua] [<man khu:> [tua [Dem nán]]]
 shirt CLF red one CLF it BE CLF Dem
 ‘the one red shirt, <it is> that one’

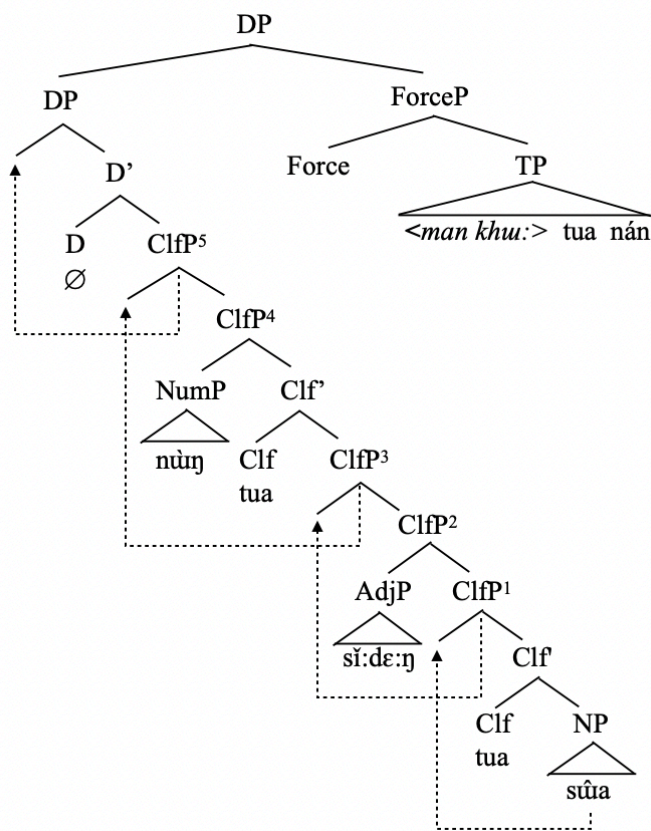

b. Quadruple CLF-Mod sequence

sũa [tua [Adj sǐ:de:ŋ]] [[Num nùŋ] tua] [<man khu:> [tua [RC thǐ: chán sủ: ma:]]]
 shirt CLFred one CLF it BE CLF that I buy ASP
 [<man khu:> [tua [Dem nán]]]
 it BE CLF Dem
 ‘the one red shirt, <it is> the one that I have bought, <it is> that one’

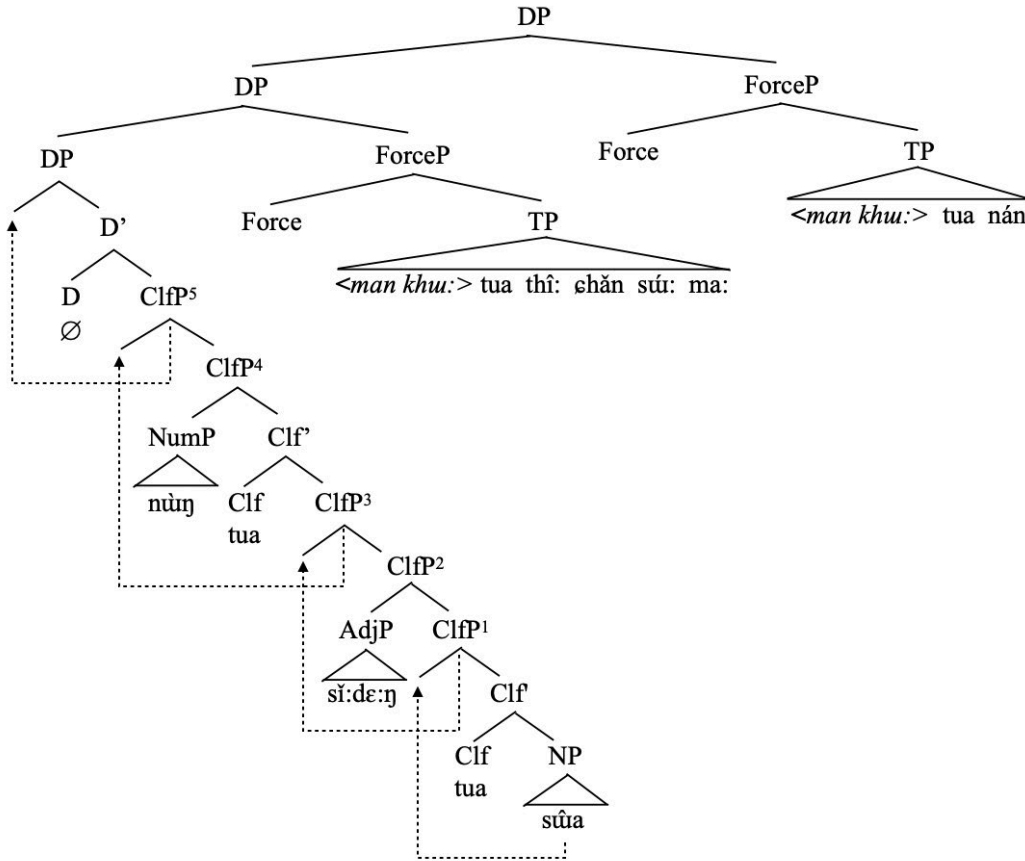

We have seen how the structures of Thai complex nominals are potentially represented through the results of the experiment. The continuous nominals containing a single or a double CLF-Mod sequence are assumed to resemble the structure of restrictive relative clauses while the ones that contain a triple or a quadruple CLF-Mod sequence are assumed to resemble the structure of appositive relative clauses. Whether the participants process the nominals with a triple or a quadruple CLF-Mod sequence similarly to the paused nominals or not is an open question and beyond the scope of this study. Instead, I will attempt to account for the reason why the structure of a continuous nominal only allows a maximum of two CLF-Mod sequences in a row, but not three and four. In other words, the structure somehow disallows movement to the Spec of ClfP⁶, as shown in (29) (cf. (28a))⁹.

⁹ One of the anonymous reviewers suggests that the non-existence of the final CLF-Mod sequence *tua nán* in the continuous string in (29) could possibly be explained by haplogy, the optional operation of omitting adjacent linguistic units that usually affects functional elements rather than lexical heads (Neeleman and van de Koot 2017). However, the same judgment holds for the non-adjacent classifiers *tua*.

- (i) sũa [tua [Adj sǐ:de:ŋ]] [tua [RC thǐ: chán sủ: ma:]] *[tua [Dem nán]]
 shirt CLF red CLF that I buy ASP CLF Dem
 ‘that red shirt that I have bought’

- (29) a. sũa [tua [Adj sǐ:dɛ:ŋ]] [[Num nùŋ] tua] *[tua [Dem nán]]
 shirt CLF red one CLF CLF Dem
 ‘that one red shirt’

b.

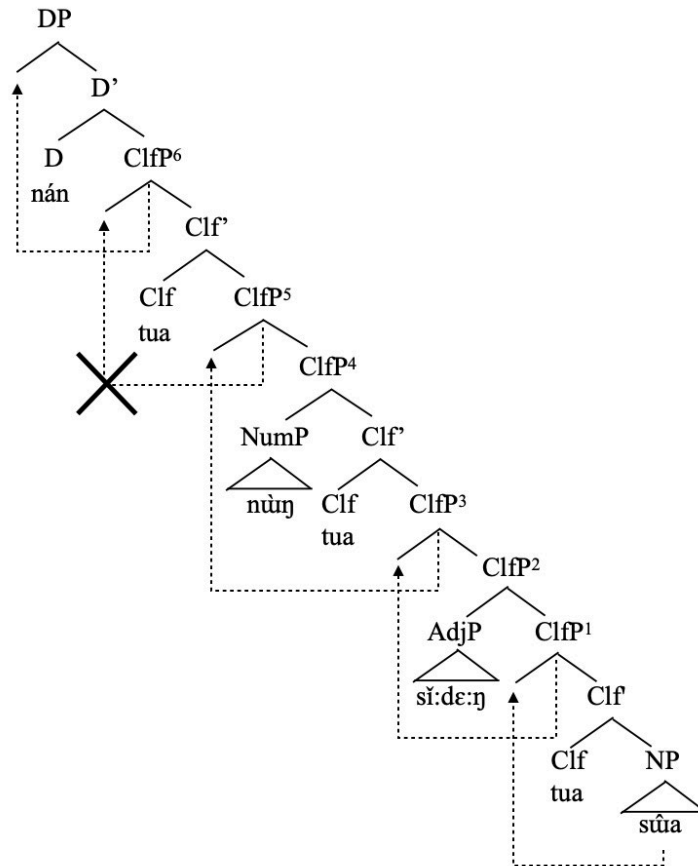

On first thought, the phenomenon looks similar to polydefinites in Greek, where the definite determiner can be multiply realized within the same nominal. However, the analyses of Greek polydefinites are concerned mainly with possible orderings and interpretations rather than the limits of their occurrences (Androutsopoulou 1995, Velegrakis 2011). Moreover, as mentioned in Footnote 4, the phenomenon cannot be analyzed in the same way as the multiple-classifier construction in Mandarin Chinese because that construction only allows multiple classifiers of different types (Liao and Wang 2011) (See Footnote 4 for examples). Again, no restrictions on the number of classifiers have ever been mentioned.

To account for the number limits of multiple CLF-Mod classifiers in Thai, potential processing costs together with grammatical constraints have been considered. It might be the case that, in Thai, each position that is a landing site for obligatory roll-up movement should not carry more than one head of the same category in each move. When there is more than one head of the same category inside the node, that node becomes “heavy”. According to the structure in (29b), the sister of ClfP⁴, which is the landing site of the ClfP³ movement, is considered heavy because it is carrying two CLF heads. Therefore, if the movement keeps rolling up and reaches the Spec of ClfP⁶, that node will have already carried three CLF heads and will be “too heavy” for the movement to continue moving. “Heaviness” plays a crucial role in language processing literature as it can impose as much processing load as the processing of *wh*-movement (Fodor 1978 and 1989, Frazier and Clifton 1989, Pickering and Traxler 2003, Aoshima et al. 2004). The structure in (30) illustrates the post-movement structure of (29b), where the movement cannot proceed any further because ClfP⁶ is now too heavy.

(30)

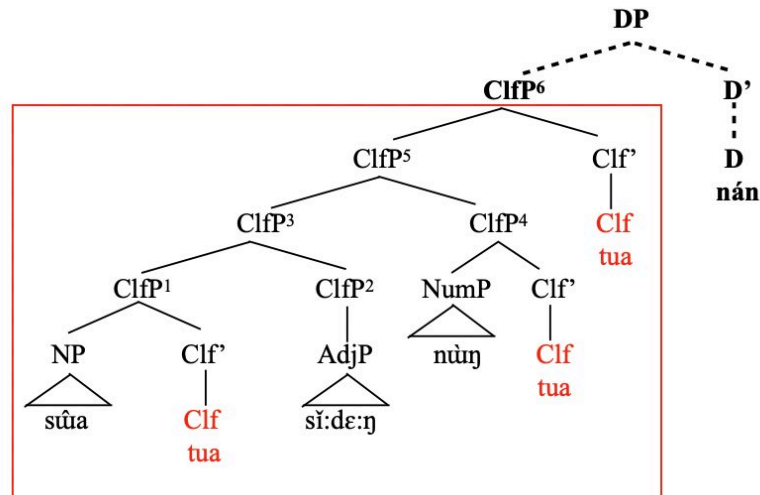

The idea of heaviness can also account for the grammatical degradation of Thai nominals that contain multiple elements of the same category. For example, Thai does not favor multiple adjectives without being coordinated (31a) or relativized (31b), unlike English.

- (31) a. Thai: ?thúʔrian [Adj mǎn] [Adj sǔaj] mák phɛ:ŋ
 durian smelly beautiful usually expensive
 thúʔrian [Adj mǎn] léʔ [Adj sǔaj] mák phɛ:ŋ
 durian smelly and beautiful usually expensive
 English: [Adj Beautiful] [Adj smelly] durians are usually expensive.
 [Adj Beautiful] and [AdjP [Adj smelly]] durians are usually expensive.
- b. Thai: ?kháw pa: hǐn [Adj kàwkè:] [[Adj nàk] mâ:k] loŋ phú:n
 he throw rock ancient heavy very down ground
 kháw pa: hǐn [Adj kàwkè:] thî: [[Adj nàk] mâ:k] loŋ phú:n
 he throw rock ancient REL heavy very down ground
 English: He threw a [very [Adj heavy] [Adj ancient] rock to the ground.
 He threw an [Adj ancient] rock that's [very [Adj heavy]] to the ground.

The preference for high attachment can indicate not only that the construction behaves similar to an appositive but also that the participants might implicitly produce a prosodic cue to reduce their processing burden. If my assumption of heaviness is correct, we are able to account for why only two CLF-Mod sequences are allowed in the structure. However, more work is needed to understand also ‘why’ (and probably ‘how’) only high attachment is strongly preferred by the participants when there are more than two CLF-Mod sequences inside a DP.

4 Conclusion

The experiment results suggest that Thai complex nominals that contain multiple CLF-Mod sequences require two distinct syntactic structures. For the nominals that have only one CLF-Mod sequence, the sequence tends to attach the lower DP in the structure. For those with two CLF-Mod sequences, the repeating sequence is likely to be ambiguous between high and low attachment interpretations, corresponding to the attachment results of restrictive relative clauses in Dillon et al. (2018). I propose that these two types of nominals have embedded structures similar to restrictive relative clauses and that the entire DP undergoes obligatory roll-up movement, following Singhapreecha (2001) and Piriya-wiboon (2010). On the other hand, the final repeating sequence of the nominals containing three and four CLF-Mod sequences behaves exactly like an appositive relative clause and a nominal appositive in that it cannot attach to the lower DP in the structure. We have thus answered our initial research questions regarding the limits of the CLF-Mod sequences within a single nominal and their syntactic structures: the number of CLF-Mod sequences affects how the speakers comprehend the nominals (preference for high attachment between the single/double and triple/quadruple CLF-Mod

sequences); and the fact that they comprehend such nominals differently reflects different syntactic structures. Given our results, moreover, we can now confirm whether our hypotheses can be accepted. The list of the hypotheses in (24) is repeated again in (32).

(32) **Hypothesis 1:** The nominal containing one CLF-Mod sequence (no repeating CLF-Mod sequence) is not appositive.

The preference for low attachment suggests that the nominal without a repeating CLF-Mod sequence should not be interpreted as appositive and its structure should be restrictive, similar to that of a restrictive relative clause.

Hypothesis 2: If the nominal already contains one CLF-Mod sequence, adding the CLF-Demonstrative sequence would turn it into an appositive.

Recall that there is no significant effect of modifier type for the repeating CLF-Mod sequence. Therefore, whether the added sequence is CLF-Adj, Num-CLF, CLF-RC or CLF-Dem, if it occurs as the second CLF-Mod sequence, its interpretation is likely to be ambiguous between high and low attachment. This suggests that the sequence does not have to always be interpreted as appositive, hence contrary to the claim that the prosodic break must be inserted before the repeating CLF-Mod sequence and as such needs recourse to apposition.

Hypothesis 3: If the nominal already contains one CLF-Mod sequence, adding another one (of any kind) may turn it into an appositive.

Same as Hypothesis 2, the second CLF-Mod sequence is ambiguous and it is not the case that high attachment is always preferred.

Hypothesis 4: If the second CLF-Mod sequence (the first repeating CLF-Mod sequence) is appositive, the third and fourth ones are also appositive.

The experiment results show that the final sequence of the nominals containing three and four CLF-Mod sequences always attaches high in the structure (68% and 78%, respectively). This fact holds true regardless of what interpretations the second sequence CLF-Mod has. The third and fourth CLF-Mod sequences are possibly the true cases of apposition.

References

- Androutsopoulou, Antonia. 1995. The licensing of adjectival modification. *Proceedings of WCCFL 13*. Stanford: CSLI Publications.
- Aoshima Sachiko, Colin Phillips, and Amy Weinberg. 2003. Processing filler-gap dependencies in a head-final language. *Journal of Memory and Language* 51:23–54.
- Bates, Douglas, Martin Maechler, Ben Bolker, and Steven Walker. 2014. lme4: Linear mixed-effects models using Eigen and S4. R package version 1.1-7. Web. <http://CRAN.R-project.org/package=lme4>
- Carlson, Greg. 1977. Amount relatives. *Language* 53:520–542.
- Chierchia, Gennaro, and Sally McConnell-Ginet. 1990. *Meaning and Grammar: An introduction to Semantics*. Cambridge, MA: MIT Press.
- Cinque, Guglielmo. 1999. *Adverbs and functional heads: A crosslinguistic perspective*. New York/Oxford: Oxford University Press.
- de Vries, Mark. 2000. Appositive relative clauses. *Linguistics in the Netherlands* 17:221–231.
- de Vries, Mark. 2006. The syntax of appositive relativization: On specifying coordination, false free relatives, and promotion. *Linguistic Inquiry* 37:229–270.
- Del Gobbo, Francesca. 2003. Appositives at the interface. Doctoral dissertation, UC Irvine.

- Dillon, Brian, Lyn Frazier, and Charles Clifton. 2018. No longer an orphan: Evidence for appositive attachment from sentence comprehension. *Glossa* 187.
- Faller, Martina. 2002. Semantics and pragmatics of evidentials in Cuzco Quechua. Doctoral dissertation, Stanford University.
- Grosu, Alexander, and Fred Landman. 1998. Strange relatives of the third kind. *Natural Language Semantics* 6:125-170.
- Jackendoff, Ray. 1977. *X'-syntax: A study of phrase structure*. Cambridge, MA: MIT Press.
- Fodor, Janet D. 1978. Parsing strategies and constraints on transformations. *Linguistic Inquiry* 9:427-473.
- Fodor, Janet D. 1989. Empty categories in sentence processing. *Language and Cognitive Processes* 4:155-210.
- Frazier, Lyn, and Charles Clifton Jr. 1989. Successive cyclicity in the grammar and the parser. *Language and Cognitive Processes* 28:331-344.
- Jenks, Peter S. E. 2011. The hidden structure of Thai noun phrases. Doctoral Dissertation, Harvard University.
- Kayne, Richard S. 1994. *The antisymmetry of syntax*. Cambridge, MA: MIT Press.
- Koev, Todor. 2013. Apposition and the structure of discourse. Doctoral dissertation, Rutgers University.
- Kookiattikoon, Supath. 2001. The syntax of classifiers in Thai. Doctoral Dissertation, University of Kansas.
- Liao, Wei-wen R., and Yuyun I Wang. 2011. Multiple-classifier constructions and nominal expressions in Chinese. *Journal of East Asian Linguistics* 20.2:145-168.
- Neeleman, Ad, and Hans van de Koot. 2017. Syntactic haplology. in *The Wiley Blackwell Companion to Syntax*, 2nd ed., ed. by Martin Everaert & Henk C. van Riemsdijk. New Jersey: Wiley.
- Pickering, Martin J. & Matthew J Traxler. 2003. Evidence against the use of subcategorization frequencies in the processing of unbounded dependencies. *Language and Cognitive Processes* 18:469-503.
- Piriyawiboon, Nattaya. 2010. Classifiers and determiner-less languages: The case of Thai. Doctoral Dissertation, University of Toronto.
- Potts, Christopher. 2005. *The logic of conventional implicatures*. Oxford: Oxford University Press.
- Rizzi, Luigi. 1997. The fine structure of the left periphery. in *Elements of Grammar*, ed. by Liliane Haegeman, 281-337. Dordrecht: Kluwer.
- Ross, John R. 1967. Constraints on variables in syntax. Doctoral dissertation. Cambridge, MA: Massachusetts Institute of Technology.
- Schlenker, Philippe. 2010a. Supplements within a unidimensional semantics I: scope. in *Proceedings of the Amsterdam Colloquium 2009*.
- Schlenker, Philippe. 2010b. Supplements within a unidimensional semantics II: epistemic status and projection. in *Proceedings of NELS 40*.
- Singhapreecha, Pornsiri. 2001. Thai classifiers and the structure of complex Thai nominals. in *Proceedings of the 15th Pacific Asia Conference on Language, Information, and Communication*, ed. by B.K. T'sou, O.O.Y. Kwong, and T.B. Lai, 259-270. City University of Hong Kong: Language Information Sciences Research Center.
- Thompson, Sandra A. 1971. The deep structure of relative clauses. in *Studies in Linguistic Semantics*, ed. by Charles J. Fillmore, and D. Terence Langendoen, 79-96. New York: Holt, Rinehart, and Winston.
- Velegrakis, Nikolaos. 2011. The syntax of Greek polydefinites. Doctoral dissertation, UCL.
- Visonyangoon, Saisunee. 2000. Parallelism between noun phrases and clauses in Thai. Doctoral Dissertation, Michigan State University.
- Wagner, Michael, and Duane G. Watson. 2010. Experimental and theoretical advances in prosody: A review. *Language and cognitive processes* 25.7-9:905-945.

Reviewed: Received 20 January 2020, revised text accepted 10 July 2021, published 1 September 2021

Editors: Editor-In-Chief Dr Mark Alves | Managing Eds. Dr Paul Sidwell, Dr Nathan Hill, Dr Sigrid Lew